























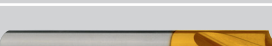



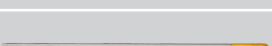

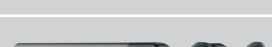
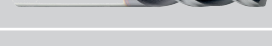
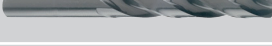

# BOHREN HSS & HSSE DRILLING HSS & HSSE











	ARTIKEL-BESCHREIBUNG ARTICLE-DESCRIPTION		ARTIKEL-NR. ARTICLE-NO.	SEITE PAGE	STAHL	INOX	NE-METALLE	GUSS	TITAN	HRC	GRAPHIT	
	HSS-E	ähnl. DIN 1899	E.2601.0	3	✓		✓					
	HSS-E		E.2621.0	4	✓	✓	✓	✓				
	HSS-E	 TIN	E.2621.1	4	✓	✓	✓	✓				
	HSS-E	 TIN	SET.2621.1	4	✓	✓	✓	✓				
	HSS-E	 LH	E.2623.0	4	✓	✓	✓	✓				
	HSS-E	 TIN	E.2647.1	4	✓	✓	✓	✓				
	HSS-E		E.2622.0	5	✓	✓	✓	✓				
	HSS-E	 TIN	E.2622.1	5	✓	✓	✓	✓				
	HSS		E.2626.0	5	✓	✓	✓	✓				
	HSS	 TIN	E.2626.1	5	✓	✓	✓	✓				
	HSS-E	DIN 1897 TIN	E.2656.1	6	✓	✓	✓	✓	✓			
	HSS-E	DIN 1897 Blue Cut	E.2603.1	6	✓	✓	✓	✓	✓			
	HSS	DIN 338 Blue Cut	E.2605.0	7 - 8	✓							
	HSS-E	DIN 338 TIN	E.2653.1	7 - 8	✓	✓	✓	✓	✓			
	HSS-E	DIN 338	E.2604.0	9 - 10		✓	✓		✓			
	HSS	DIN 338	E.2606.0	10	✓							
	HSS-E	DIN 338 TIN	SET.2653.1	11	✓	✓	✓	✓	✓			
	HSS-E	DIN 338 TIN	SET.2653.2	11	✓	✓	✓	✓	✓			
	HSS-E	DIN 338 TIN	SET.2653.3	11	✓	✓	✓	✓	✓			
	HSS-E	DIN 338 TIN	SET.2653.4	11	✓	✓	✓	✓	✓			
	HSS-E	DIN 338 TIN	SET.2653.5	11	✓	✓	✓	✓	✓			
	HSS	DIN 338	SET.2611.0 SET.2611.1	12	✓	✓	✓	✓				
	HSS-E	DIN 338	SET.2612.0	12	✓	✓	✓	✓				

Gewindebohrer	1
Bohren HSSE	2
Bohren VHM	3
Reiben HSSE	4
Reiben VHM	5
Frässtifte VHM	6
Fräsen VHM	7
WP-Werkzeuge	8
Fräsen HSSE	9
Sägen	10
Lehren	11
Nachschleifen	12
Sonstiges	13

Die angegebenen Einsatzgebiete sind Richtlinien. Die genauen Einsatzdaten finden Sie im jeweiligen Artikel!

The indicated operational areas are estimated guide lines. The exact dates of use please find at the specified articles!





















# BOHREN HSS & HSSE DRILLING HSS & HSSE

	ARTIKEL-BESCHREIBUNG ARTICLE-DESCRIPTION		ARTIKEL-NR. ARTICLE-NO.	SEITE PAGE	STAHL	INOX	NE- METALLE	GUSS	TITAN	HRC	GRAPHIT	
	HSS-E	DIN 338	SET.2614.0	12	✓	✓	✓	✓				
	HSS	DIN 338	SET.2613.0 SET.2613.1	12	✓	✓	✓	✓				
	HSS-E	DIN 340	TIN E.2615.1	13	✓	✓	✓	✓				
	HSS	WERKS- (COMPANY) NORM	E.2616.0	14-16	✓		✓					
	HSS-E	WERKS- (COMPANY) NORM	E.2617.0	14-16	✓		✓	✓				
	HSS	WERKS- (COMPANY) NORM	E.2618.0	16	✓		✓					
	HSS	DIN 345	E.2619.0	17	✓			✓				
	HSS	DIN 341	E.2607.0	18	✓							
	HSS	DIN 1870	E.2608.0	19	✓							
	HSS	DIN 1870	E.2609.0	20	✓							
	HSS	FORM A	 RH E.2631.0	21	✓	✓	✓	✓				
	HSS	FORM A	 RH SET.2631.2	21	✓	✓	✓	✓				
	HSS	FORM A	 RH SET.2631.3	21	✓	✓	✓	✓				
	HSS	FORM B	 RH E.2635.0	22	✓	✓	✓	✓				
	HSS	FORM B	 LH E.2636.0	22	✓	✓	✓	✓				
	HSS	FORM B	 RH E.2637.0	22	✓	✓	✓	✓				
	HSS-E	FORM B	 RH E.2638.0	22	✓	✓	✓	✓				
	HSS-E	FORM A	 RH E.2639.0	23	✓	✓	✓	✓				
	HSS	FORM R	 RH E.2640.0	24	✓	✓	✓	✓				
	HSS	FORM R	 LH E.2641.0	24	✓	✓	✓	✓				
	HSS-E	FORM R	 RH E.2642.0	24	✓	✓	✓	✓				
	HSS-E	 90° 130°	E.2643.0	24	✓	✓	✓	✓				
	HSS-E	 90° 130°	TIN E.2643.1	24	✓	✓	✓	✓				

Die angegebenen Einsatzgebiete sind Richtlinien. Die genauen Einsatzdaten finden Sie im jeweiligen Artikel!

The indicated operational areas are estimated guide lines. The exact dates of use please find at the specified articles!





# BOHREN HSS & HSSE DRILLING HSS & HSSE

	ARTIKEL-BESCHREIBUNG ARTICLE-DESCRIPTION	ARTIKEL-NR. ARTICLE-NO.	SEITE PAGE	STAHL	INOX	NE- METALLE	GUSS	TITAN	HRC	GRAPHIT	
	HSS 	E.2654.0	25	✓	✓	✓	✓				
	HSS 	E.2655.0	25	✓	✓	✓	✓				
	HSS 	E.2644.0	26	✓	✓	✓	✓				
	HSS  TIN	E.2644.1	26	✓	✓	✓	✓				
	HSS-E FORM D	E.2649.0	26	✓	✓	✓	✓				
	HSS-E FORM D	E.2650.0	26	✓	✓	✓	✓				
	HSS DIN 8374 OX	E.2610.0	27	✓							
	HSS OX	E.2620.0	27	✓							
	HSS OX	E.2611.0	28	✓							
	HSS DIN 8376 OX	E.2645.0	28	✓							
	HSS DIN 8375 OX	E.2612.0	29	✓							
	HSS DIN 8377 OX	E.2646.0	29	✓							
	HSS DIN 8379 OX	E.2613.0	30	✓							
		E.2614.0	31	✓	✓	✓	✓				
		E.2624.0	31								

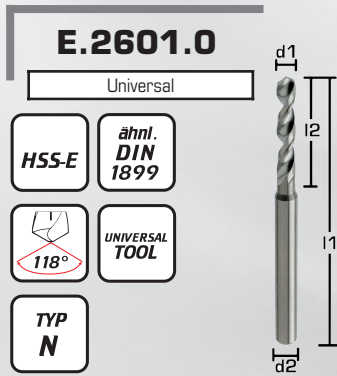
Gewindbohrer	1
Bohren HSSE	2
Bohren VHM	3
Reiben HSSE	4
Reiben VHM	5
Frässtifte VHM	6
Fräsen VHM	7
WP-Werkzeuge	8
Fräsen HSSE	9
Sägen	10
Lehren	11
Nachschleifen	12
Sonstiges	13

# HSSE-Kleinstbohrer ähnl. DIN 1899A



-  HSSE-Mini drills similar DIN 1899A
-  Wiertła miniaturowe HSS-E odpowiednik wiertel wg DIN 1899A
-  Micropunte HSSE simile DIN 1899A
-  Microbrocas en HSSE sim. DIN 1899A

Verpackungseinheit: 10 Stück/Abm.  
Unit size: 10 pieces/size

Artikel-Nr. Article-No.				E.2601.0	Artikel-Nr. Article-No.				E.2601.0
d1 0/-0,004	l2	l1	d2	€ Stück piece	d1 0/-0,004	l2	l1	d2	€ Stück piece
0,15	0,8	25	1,0		0,55	3,9	25	1,0	
0,16	1,1	25	1,0		0,56	3,9	25	1,0	
0,17	1,1	25	1,0		0,57	3,9	25	1,0	
0,18	1,1	25	1,0		0,58	3,9	25	1,0	
0,19	1,1	25	1,0		0,59	3,9	25	1,0	
0,20	1,5	25	1,0		0,60	3,9	25	1,0	
0,21	1,5	25	1,0		0,61	4,2	25	1,0	
0,22	1,5	25	1,0		0,62	4,2	25	1,0	
0,23	1,5	25	1,0		0,63	4,2	25	1,0	
0,24	1,5	25	1,0		0,64	4,2	25	1,0	
0,25	1,9	25	1,0		0,65	4,2	25	1,0	
0,26	1,9	25	1,0		0,66	4,2	25	1,0	
0,27	1,9	25	1,0		0,67	4,2	25	1,0	
0,28	1,9	25	1,0		0,68	4,8	25	1,0	
0,29	1,9	25	1,0		0,69	4,8	25	1,0	
0,30	1,9	25	1,0		0,70	4,8	25	1,0	
0,31	2,4	25	1,0		0,71	4,8	25	1,0	
0,32	2,4	25	1,0		0,72	4,8	25	1,0	
0,33	2,4	25	1,0		0,73	4,8	25	1,0	
0,34	2,4	25	1,0		0,75	4,8	25	1,0	
0,35	2,4	25	1,0		0,76	5,3	25	1,0	
0,36	2,4	25	1,0		0,77	5,3	25	1,0	
0,37	2,4	25	1,0		0,79	5,3	25	1,0	
0,38	2,4	25	1,0		0,80	5,3	25	1,5	
0,39	3,0	25	1,0		0,85	5,3	25	1,5	
0,40	3,0	25	1,0		0,90	6,0	25	1,5	
0,41	3,0	25	1,0		0,95	6,0	25	1,5	
0,42	3,0	25	1,0		1,00	6,8	25	1,5	
0,43	3,0	25	1,0		1,05	6,8	25	1,5	
0,44	3,0	25	1,0		1,10	7,6	25	1,5	
0,45	3,0	25	1,0		1,15	7,6	25	1,5	
0,47	3,0	25	1,0		1,20	8,5	25	1,5	
0,48	3,0	25	1,0		1,25	8,5	25	1,5	
0,49	3,4	25	1,0		1,30	8,5	25	1,5	
0,50	3,4	25	1,0		1,35	9,5	25	1,5	
0,51	3,4	25	1,0		1,40	9,5	25	1,5	
0,52	3,4	25	1,0		1,45	9,5	25	1,5	
0,53	3,4	25	1,0		1,50	9,5	30	2,0	

## HSSE-NC-Anbohrer

### E.2621.0

Universal

HSS-E UNIVERSAL TOOL

90°

RH

### E.2621.1

Universal

HSS-E UNIVERSAL TOOL

TIN

90°

RH

### SET.2621.1

Universal

HSSE-NC-Center drills

Wiertła centrujące HSS-E do maszyn CNC

Punte da centro HSSE

Brocas de puntear en HSSE

Artikel-Nr. Article-No.			E.2621.0 € Stück piece	E.2621.1 € Stück piece
d1	l2	l1		
2,00	8	40		
3,00	12	46		
4,00	12	55		
5,00	15	60		
6,00	20	66		
8,00	25	79		
10,00	25	89		
12,00	30	102		
14,00	34	107		
16,00	35	115		
20,00	40	131		
25,00	53	151		
<b>Satz Set</b>			<b>SET.2621.1</b>	
10 St. pc. Ø 3/4/5/6 mm 5 St. pc. Ø 8/10 mm				

## HSSE-NC-Anbohrer

### E.2623.0

Universal

HSS-E UNIVERSAL TOOL

90°

LH

### E.2647.1

Universal

HSS-E UNIVERSAL TOOL

TIN

60°

RH

### SET.2623.1

Universal

HSSE-NC-Center drills

Wiertła centrujące HSS-E do maszyn CNC

Punte da centro HSSE

Brocas de puntear en HSSE

Artikel-Nr. Article-No.			E.2623.0 € Stück piece	E.2647.1 € Stück piece
d1	l2	l1		
3,00	12	46		
4,00	12	55		
5,00	15	60		
6,00	20	66		
8,00	25	79		
10,00	25	89		
12,00	30	102		
14,00	34	107		
16,00	35	115		

- 1 Gewindbohrer
- 2 Bohren HSSE
- 3 Bohren VHM
- 4 Reiben HSSE
- 5 Reiben VHM
- 6 Frässtifte VHM
- 7 Fräsen VHM
- 8 WP-Werkzeuge
- 9 Fräsen HSSE
- 10 Sägen
- 11 Lehren
- 12 Nachschleifen
- 13 Sonstiges



## HSSE-NC-Anbohrer

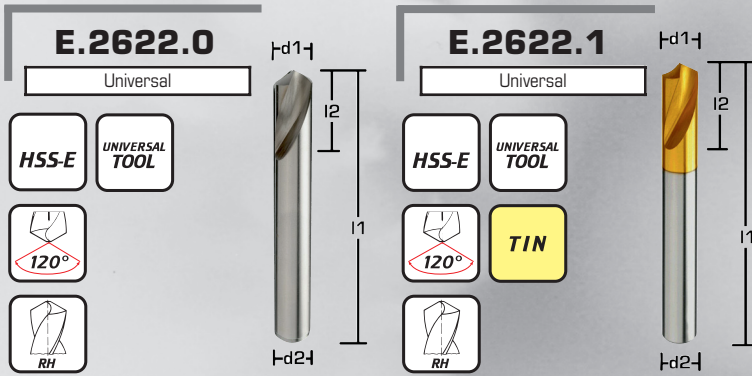

HSSE-NC-Center drills

Wiertła centrujące HSS-E do maszyn CNC

Punte da centro HSSE

Brocas de puntear en HSSE

Artikel-Nr. Article-No.			E.2622.0 € Stück piece	E.2622.1 € Stück piece
d1	l2	l1		
2,00	8	40		
3,00	12	46		
4,00	12	55		
5,00	15	60		
6,00	20	66		
8,00	25	79		
10,00	25	89		
12,00	30	102		
14,00	34	107		
16,00	35	115		
20,00	40	131		
25,00	53	151		

## HSS-NC-Anbohrer lang

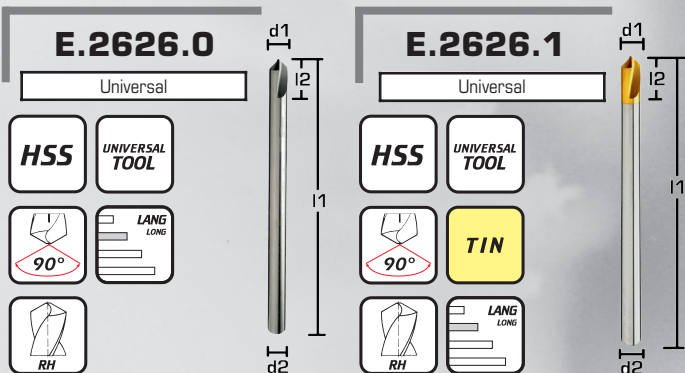

HSSE-NC-Center drills long

Wiertła centrujące długie HSS-E do maszyn CNC

Punte da centro HSSE serie lunga

Brocas de puntear en HSSE, serie larga

Artikel-Nr. Article-No.				E.2626.0 € Stück piece	E.2626.1 € Stück piece
d1	l2	l1	d2		
3,00	6	100	3,0		
4,00	6	100	4,0		
5,00	10	132	5,0		
6,00	15	139	6,0		
8,00	17	165	8,0		
10,00	20	184	10,0		
12,00	25	205	12,0		
16,00	35	227	16,0		
20,00	40	254	20,0		

# HSSE-Spiralbohrer DIN 1897 (Automaten-Stoßbohrer)

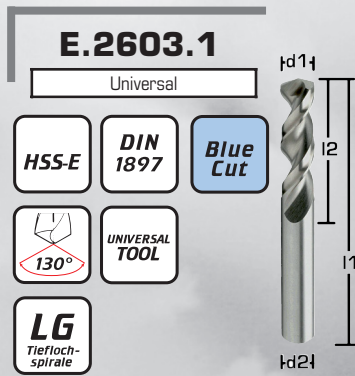
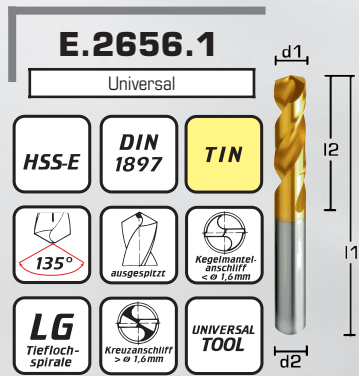

- Standard HSSE stub drills DIN 1897
- Wiertła standardowe automatowe HSS-E, wg DIN 1897
- Punte extra corte DIN 1897 HSSE
- Brocas en HSSE extracortas DIN 1897

Verpackungseinheit: bis Ø 6,5 mm 10 Stück/Abm., ab Ø 6,5 mm 5 Stück/Abm.  
 Unit size: up to Ø 6,5 mm 10 pieces/size, from Ø 6,5 mm 5 pieces/size

E.2656.1			E.2603.1			E.2656.1			E.2603.1			E.2656.1			E.2603.1		
Artikel.-Nr.	Art.-No.		Artikel.-Nr.	Art.-No.		Artikel.-Nr.	Art.-No.		Artikel.-Nr.	Art.-No.		Artikel.-Nr.	Art.-No.		Artikel.-Nr.	Art.-No.	
d1	l2	l1	d1	l2	l1	d1	l2	l1	d1	l2	l1	d1	l2	l1	d1	l2	l1
€	Stück	piece	€	Stück	piece	€	Stück	piece	€	Stück	piece	€	Stück	piece	€	Stück	piece
1,00	6	26				5,20	26	62				9,25	40	84			
1,10	7	28				5,25	26	62				9,30	40	84			
1,20	8	30				5,30	26	62				9,35	40	84			
1,25	8	30				5,40	28	66				9,40	40	84			
1,30	8	30				5,50	28	66				9,50	40	84			
1,40	9	32				5,55	28	66				9,60	43	89			
1,50	9	32				5,60	28	66				9,70	43	89			
1,60	10	34				5,70	28	66				9,75	43	89			
1,70	10	34				5,75	28	66				9,80	43	89			
1,75	11	36				5,80	28	66				9,90	43	89			
1,80	11	36				5,90	28	66				10,00	43	89			
1,90	11	36				6,00	28	66				10,20	43	89			
2,00	12	38				6,10	31	70				10,25	43	89			
2,10	12	38				6,20	31	70				10,50	43	89			
2,20	13	40				6,25	31	70				10,75	47	95			
2,25	13	40				6,30	31	70				11,00	47	95			
2,30	13	40				6,40	31	70				11,25	47	95			
2,40	14	43				6,50	31	70				11,50	47	95			
2,50	14	43				6,60	31	70				11,75	47	95			
2,60	14	43				6,70	31	70				11,80	47	95			
2,70	16	46				6,75	34	74				12,00	51	102			
2,75	16	46				6,80	34	74				12,25	51	102			
2,80	16	46				6,90	34	74				12,50	51	102			
2,90	16	46				7,00	34	74				12,75	51	102			
3,00	16	46				7,10	34	74				13,00	51	102			
3,10	18	49				7,20	34	74				13,50	54	107			
3,20	18	49				7,25	34	74				13,80	54	107			
3,25	18	49				7,30	34	74				14,00	54	107			
3,30	18	49				7,40	34	74				14,50	56	111			
3,40	20	52				7,45	34	74				15,00	56	111			
3,50	20	52				7,50	34	74				15,50	58	115			
3,60	20	52				7,60	37	79				16,00	58	115			
3,70	20	52				7,70	37	79				16,50	60	119			
3,75	20	52				7,75	37	79				17,00	60	119			
3,80	22	55				7,80	37	79				17,50	62	123			
3,90	22	55				7,90	37	79				18,00	62	123			
4,00	22	55				8,00	37	79				18,50	64	127			
4,10	22	55				8,10	37	79				19,00	64	127			
4,20	22	55				8,20	37	79				19,50	66	131			
4,25	22	55				8,25	37	79				20,00	66	131			
4,30	24	58				8,30	37	79				20,50	68	136			
4,40	24	58				8,40	37	79				21,00	68	136			
4,50	24	58				8,50	37	79				21,50	70	141			
4,60	24	58				8,60	40	84				22,00	70	141			
4,65	24	58				8,70	40	84				22,50	72	146			
4,70	24	58				8,75	40	84				23,00	72	146			
4,75	24	58				8,80	40	84				23,50	72	146			
4,80	26	62				8,90	40	84				24,00	75	151			
4,90	26	62				9,00	40	84				24,50	75	151			
5,00	26	62				9,10	40	84				25,00	75	151			
5,10	26	62				9,20	40	84				31,00	87	174			

- 1 Gewindebohrer
- 2 Bohren HSSE
- 3 Bohren VHM
- 4 Reiben HSSE
- 5 Reiben VHM
- 6 Frässtifte VHM
- 7 Fräsen VHM
- 8 WP-Werkzeuge
- 9 Fräsen HSSE
- 10 Sägen
- 11 Lehren
- 12 Nachschleifen
- 13 Sonstiges

# HSS/HSSE-Spiralbohrer DIN 338

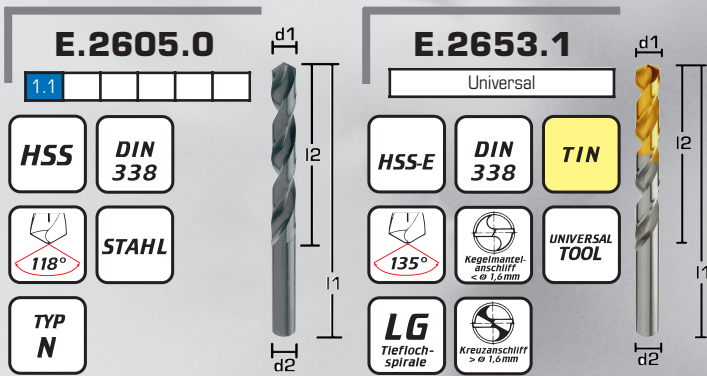

HSS-Twist drills DIN 338

Wiertła skrotne HSS/HSS-E wg DIN 338

Punte corte DIN 338 HSS

Brocas helicoidales DIN 338 HSS

Verpackungseinheit:  
bis Ø 6,5 mm 10 St./Abm., ab Ø 6,5 mm 5 St./Abm.  
Unit size:  
up to Ø 6,5 mm 10 pc./size, from Ø 6,5 mm 5 pc./size

Art.-Nr. Art.-No.			E.2605.0		E.2653.1		Art.-Nr. Art.-No.			E.2605.0		E.2653.1		Art.-Nr. Art.-No.			E.2605.0		E.2653.1	
d1	l2	l1	Stück	piece	Stück	piece	d1	l2	l1	Stück	piece	Stück	piece	d1	l2	l1	Stück	piece	Stück	piece
0,20	3	19					1,98	24	49					4,15	43	75				
0,21	3	19					1,99	24	49					4,20	43	75				
0,22	3	19					2,00	24	49					4,25	43	75				
0,25	3	19					2,02	24	49					4,30	47	80				
0,30	3	19					2,03	24	49					4,35	47	80				
0,35	4	19					2,04	24	49					4,40	47	80				
0,40	5	20					2,05	24	49					4,45	47	80				
0,45	5	20					2,06	24	49					4,50	47	80				
0,49	6	22					2,10	24	49					4,55	47	80				
0,50	6	22					2,13	27	53					4,60	47	80				
0,55	7	24					2,15	27	53					4,65	47	80				
0,60	7	24					2,20	27	53					4,70	47	80				
0,62	8	26					2,25	27	53					4,75	47	80				
0,65	8	26					2,30	27	53					4,80	52	86				
0,68	9	28					2,35	27	53					4,85	52	86				
0,70	9	28					2,40	30	57					4,90	52	86				
0,72	9	28					2,45	30	57					4,95	52	86				
0,73	9	28					2,50	30	57					5,00	52	86				
0,75	9	28					2,55	30	57					5,05	52	86				
0,80	10	30					2,60	30	57					5,10	52	86				
0,81	10	30					2,63	30	57					5,15	52	86				
0,83	10	30					2,65	30	57					5,20	52	86				
0,85	10	30					2,70	33	61					5,25	52	86				
0,90	11	32					2,75	33	61					5,30	52	86				
0,92	11	32					2,80	33	61					5,35	57	93				
0,94	11	32					2,85	33	61					5,40	57	93				
0,95	11	32					2,90	33	61					5,45	57	93				
1,00	12	34					2,94	33	61					5,50	57	93				
1,05	12	34					2,95	33	61					5,55	57	93				
1,10	14	36					3,00	33	61					5,60	57	93				
1,13	14	36					3,05	36	65					5,65	57	93				
1,15	14	36					3,10	36	65					5,70	57	93				
1,20	16	38					3,15	36	65					5,75	57	93				
1,22	16	38					3,20	36	65					5,80	57	93				
1,25	16	38					3,25	36	65					5,85	57	93				
1,30	16	38					3,30	36	65					5,90	57	93				
1,35	18	40					3,35	36	65					5,95	57	93				
1,40	18	40					3,40	39	70					6,00	57	93				
1,43	18	40					3,45	39	70					6,05	63	101				
1,45	18	40					3,50	39	70					6,10	63	101				
1,50	18	40					3,55	39	70					6,15	63	101				
1,55	20	43					3,60	39	70					6,20	63	101				
1,60	20	43					3,62	39	70					6,25	63	101				
1,62	20	43					3,65	39	70					6,30	63	101				
1,63	20	43					3,70	39	70					6,35	63	101				
1,65	20	43					3,75	39	70					6,40	63	101				
1,70	20	43					3,80	43	75					6,45	63	101				
1,75	22	46					3,85	43	75					6,50	63	101				
1,80	22	46					3,90	43	75					6,55	63	101				
1,83	22	46					3,95	43	75					6,60	63	101				
1,85	22	46					4,00	43	75					6,65	63	101				
1,90	22	46					4,05	43	75					6,70	63	101				
1,95	24	49					4,10	43	75											



# HSS/HSSE-Spiralbohrer DIN 338

**E.2605.0**

1.1

HSS DIN 338

118° STAHL

TYP N

**E.2653.1**

Universal

HSS-E DIN 338 TIN

135° Kegelmantel-schneid <math>\le \varnothing 1,6\text{mm}</math> UNIVERSAL TOOL

LG Tiefloch-spirale Kreuzschliff >  $\varnothing 1,6\text{mm}</math>$

HSS-Twist drills DIN 338

Wiertła skrotne HSS/HSS-E wg DIN 338

Punte corte DIN 338 HSS

Brocas helicoidales DIN 338 HSS

Verpackungseinheit:  
bis  $\varnothing 6,5\text{ mm}$  10 St./Abm., ab  $\varnothing 6,5\text{ mm}$  5 St./Abm.  
Unit size:  
up to  $\varnothing 6,5\text{ mm}$  10 pc./size, from  $\varnothing 6,5\text{ mm}$  5 pc./size

Art.-Nr. Art.-No.			E.2605.0		E.2653.1		Art.-Nr. Art.-No.			E.2605.0		E.2653.1		Art.-Nr. Art.-No.			E.2605.0		E.2653.1	
d1	l2	l1	€	Stück piece	€	Stück piece	d1	l2	l1	€	Stück piece	€	Stück piece	d1	l2	l1	€	Stück piece	€	Stück piece
6,75	69	109					9,35	81	125					13,30	108	160				
6,80	69	109					9,40	81	125					13,40	108	160				
6,85	69	109					9,45	81	125					13,50	108	160				
6,90	69	109					9,50	81	125					13,60	108	160				
6,95	69	109					9,55	87	133					13,70	108	160				
7,00	69	109					9,60	87	133					13,75	108	160				
7,05	69	109					9,65	87	133					13,80	108	160				
7,10	69	109					9,70	87	133					13,90	108	160				
7,15	69	109					9,75	87	133					14,00	108	160				
7,20	69	109					9,80	87	133					14,10	114	169				
7,25	69	109					9,85	87	133					14,20	114	169				
7,30	69	109					9,90	87	133					14,25	114	169				
7,35	69	109					9,95	87	133					14,30	114	169				
7,40	69	109					10,00	87	133					14,40	114	169				
7,45	69	109					10,10	87	133					14,50	114	169				
7,50	69	109					10,20	87	133					14,60	114	169				
7,55	75	117					10,25	87	133					14,70	114	169				
7,60	75	117					10,30	87	133					14,75	114	169				
7,65	75	117					10,40	87	133					14,80	114	169				
7,70	75	117					10,50	87	133					14,90	114	169				
7,75	75	117					10,60	87	133					15,00	114	169				
7,80	75	117					10,70	94	142					15,25	120	178				
7,85	75	117					10,75	94	142					15,50	120	178				
7,90	75	117					10,80	94	142					15,75	120	178				
7,95	75	117					10,90	94	142					15,80	120	178				
8,00	75	117					11,00	94	142					16,00	120	178				
8,05	75	117					11,10	94	142					16,20	125	184				
8,10	75	117					11,20	94	142					16,25	125	184				
8,15	75	117					11,25	94	142					16,50	125	184				
8,20	75	117					11,30	94	142					16,75	125	184				
8,25	75	117					11,40	94	142					16,80	125	184				
8,30	75	117					11,50	94	142					17,00	125	184				
8,35	75	117					11,60	94	142					17,25	130	191				
8,40	75	117					11,70	94	142					17,50	130	191				
8,45	75	117					11,75	94	142					17,75	130	191				
8,50	75	117					11,80	94	142					18,00	130	191				
8,55	81	125					11,90	101	151					18,25	135	198				
8,60	81	125					12,00	101	151					18,50	135	198				
8,65	81	125					12,10	101	151					18,75	135	198				
8,70	81	125					12,20	101	151					19,00	135	198				
8,75	81	125					12,25	101	151					19,50	140	205				
8,80	81	125					12,30	101	151					19,75	140	205				
8,85	81	125					12,40	101	151					20,00	140	205				
8,90	81	125					12,50	101	151											
8,95	81	125					12,60	101	151											
9,00	81	125					12,70	101	151											
9,05	81	125					12,75	101	151											
9,10	81	125					12,80	101	151											
9,15	81	125					12,90	101	151											
9,20	81	125					13,00	101	151											
9,25	81	125					13,20	101	151											
9,30	81	125					13,25	108	160											

- 1 Gewindebohrer
- 2 Bohren HSSE
- 3 Bohren VHM
- 4 Reiben HSSE
- 5 Reiben VHM
- 6 Frässtifte VHM
- 7 Fräsen VHM
- 8 WP-Werkzeuge
- 9 Fräsen HSSE
- 10 Sägen
- 11 Lehren
- 12 Nachschleifen
- 13 Sonstiges

# HSSE-Inox/Titan-Spiralbohrer DIN 338

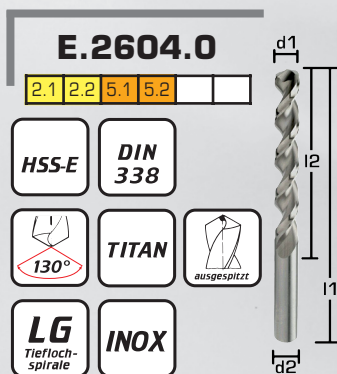

**E.2604.0**

2.1 2.2 5.1 5.2

HSS-E DIN 338

130° TITAN

ausgespitzt

LG Tiefloch-spirale INOX

HSSE-Stainless steels twist drills DIN 338

Wiertła skrętne HSS-E wg DIN 338 do stali nierdzewnych tytanowych, kobaltowych

Punte corte DIN 338 HSSE lavorazione acciai inossidabili

Brocas helicoidales DIN 338 en HSSE para inoxidable

\* = Auslaufartikel  
\* = no future production anymore

Verpackungseinheit: bis Ø 6,5 mm 10 Stück/Abm., ab Ø 6,5 mm 5 Stück/Abm.  
Unit size: up to Ø 6,5 mm 10 pieces/size, from Ø 6,5 mm 5 pieces/size



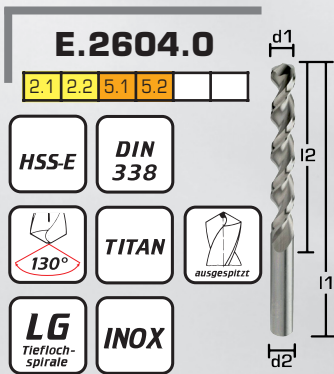

Artikel-Nr. Article-No.			E.2604.0	Artikel-Nr. Article-No.			E.2604.0
d1	l2	l1	€ Stück piece	d1	l2	l1	€ Stück piece
0,40	5	20		3,80	43	75	
0,50	6	22		3,90	43	75	
0,60	7	24		3,95*	43	75	
0,70	9	28		4,00	43	75	
0,80	10	30		4,05*	43	75	
0,90	11	32		4,10	43	75	
1,00	12	34		4,20	43	75	
1,10	14	36		4,30	47	80	
1,15*	14	36		4,40	47	80	
1,20	16	38		4,45*	47	80	
1,25*	16	38		4,50	47	80	
1,30	16	38		4,60	47	80	
1,35*	18	40		4,65*	47	80	
1,40	18	40		4,70	47	80	
1,45*	18	40		4,80	52	86	
1,50	18	40		4,90	52	86	
1,55*	20	43		5,00	52	86	
1,60	20	43		5,10	52	86	
1,70	20	43		5,20	52	86	
1,80	22	46		5,30	52	86	
1,85*	22	46		5,40	57	93	
1,90	22	46		5,50	57	93	
1,95*	24	49		5,55*	57	93	
2,00	24	49		5,60	57	93	
2,05*	24	49		5,70	57	93	
2,10	24	49		5,80	57	93	
2,15*	27	53		5,90	57	93	
2,20	27	53		6,00	57	93	
2,30	27	53		6,10	63	101	
2,35*	27	53		6,20	63	101	
2,40	30	57		6,30	63	101	
2,45*	30	57		6,40	63	101	
2,50	30	57		6,50	63	101	
2,53*	30	57		6,55*	63	101	
2,55*	30	57		6,60	63	101	
2,60	30	57		6,70	63	101	
2,70	33	61		6,80	69	109	
2,75*	33	61		6,90	69	109	
2,80	33	61		7,00	69	109	
2,90	33	61		7,10	69	109	
3,00	33	61		7,20	69	109	
3,05*	36	65		7,30	69	109	
3,10	36	65		7,40	69	109	
3,15*	36	65		7,45*	69	109	
3,20	36	65		7,50	69	109	
3,30	36	65		7,60	75	117	
3,40	39	70		7,70	75	117	
3,45*	39	70		7,80	75	117	
3,50	39	70		7,90	75	117	
3,60	39	70		8,00	75	117	
3,65*	39	70		8,10	75	117	
3,70	39	70		8,20	75	117	

## HSSE-Inox/Titan-Spiralbohrer DIN 338



\* = Auslaufartikel  
\* = no future production anymore





Verpackungseinheit: bis Ø 6,5 mm 10 Stück/Abm., ab Ø 6,5 mm 5 Stück/Abm.  
Unit size: up to Ø 6,5 mm 10 pieces/size, from Ø 6,5 mm 5 pieces/size

-  HSSE-Stainless steels twist drills DIN 338
-  Wiertła skrętnie HSS-E wg DIN 338 do stali nierdzewnych tytanowych, kobaltowych
-  Punte corte DIN 338 HSSE lavorazione acciai inossidabili
-  Brocas helicoidales DIN 338 en HSSE para inoxidable

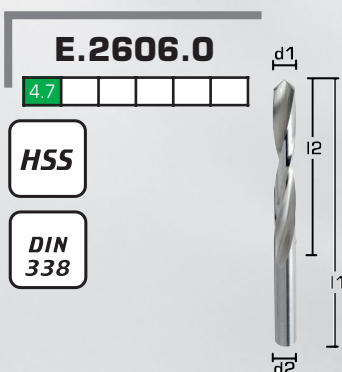
Artikel-Nr. Article-No.			E.2604.0	Artikel-Nr. Article-No.			E.2604.0
d1	l2	l1	€ Stück piece	d1	l2	l1	€ Stück piece
Ø 0,4 - 8,2 mm siehe Seite 2.09				Ø 0,4 - 8,2 mm see page 2.09			
8,30	75	117		9,90	87	133	
8,40	75	117		10,00	87	133	
8,50	75	117		10,20	87	133	
8,60	81	125		10,50	87	133	
8,70	81	125		10,80	94	142	
8,80	81	125		10,90*	94	142	
8,90	81	125		11,00	94	142	
8,90	81	125		11,20	94	142	
9,00	81	125		11,50	94	142	
9,10	81	125		12,00	101	151	
9,20	81	125		12,50	101	151	
9,30	81	125		12,80	101	151	
9,40	81	125		13,00	101	151	
9,50	81	125		14,00	108	160	
9,60	87	133		16,00	120	178	
9,70	87	133					
9,80	87	133					

## HSS-Spezial-Spiralbohrer für Plexiglas



-  HSS-Special twist drills for plexiglas
-  Wiertła specjalne skrętnie HSS do tworzyw sztucznych typu plexyglasu
-  Punte speciali HSS per plexiglass
-  Brocas en HSS especialmente para Plexiglas

Artikel-Nr. Article-No.			E.2606.0	Artikel-Nr. Article-No.			E.2606.0
d1	l2	l1	€ Stück piece	d1	l2	l1	€ Stück piece
2,00	24	49		5,50	57	93	
2,50	30	57		6,00	57	93	
3,00	33	61		6,50	63	101	
3,30	36	65		6,80	69	109	
3,50	39	70		7,00	69	109	
4,00	43	75		8,00	75	117	
4,20	43	75		8,50	75	117	
4,50	47	80		10,00	87	133	
5,00	52	86		12,00	101	151	

- 1 Gewindebohrer
- 2 Bohren HSSE
- 3 Bohren VHM
- 4 Reiben HSSE
- 5 Reiben VHM
- 6 Frässtifte VHM
- 7 Fräsen VHM
- 8 WP-Werkzeuge
- 9 Fräsen HSSE
- 10 Sägen
- 11 Lehren
- 12 Nachschleifen
- 13 Sonstiges

## HSSE-Spiralbohrer in Metallkassetten

### SET.2653.1

Universal

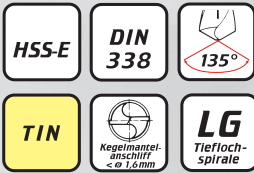

49 Stück pieces  
 $\varnothing$  1 - 10 mm  
 0,5 mm steigend rising 0,5 mm

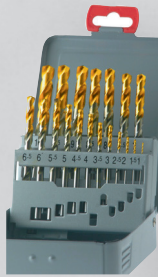

### SET.2653.2

Universal

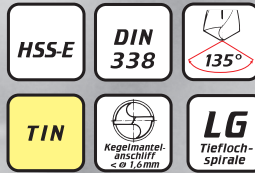

25 Stück pieces  
 $\varnothing$  1 - 13 mm  
 0,5 mm steigend rising 0,5 mm

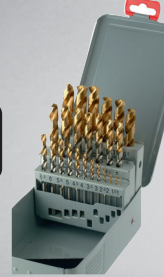

HSS-E-Twist drills in metal cassettes

Zestawy wiertel skrętnych HSS-E w metalowej kasetce

Assortimenti di punte HSSE in cassetta metallica

Brocas HSSE en estuches metálicos

SET.2653.1  
 €  
 Stück piece

SET.2653.2  
 €  
 Stück piece

### SET.2653.3

Universal

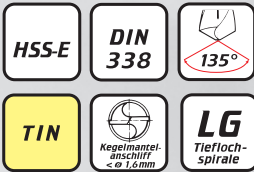

24 Stück pieces  
 $\varnothing$  1 - 10,5 mm  
 0,5 mm steigend rising 0,5 mm  
 +  $\varnothing$  3,3 / 4,2 / 6,8 / 10,2 mm

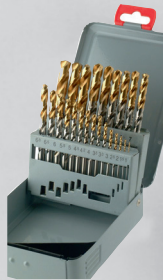

### SET.2653.4

Universal

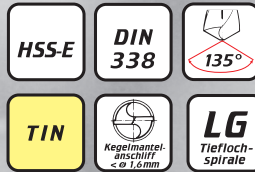

60 Stück pieces  
 $\varnothing$  1 - 5,9 mm  
 0,1 mm steigend rising 0,1 mm

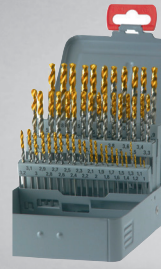

HSS-E-Twist drills in metal cassettes

Zestawy wiertel skrętnych HSS-E w metalowej kasetce

Assortimenti di punte HSSE in cassetta metallica

Brocas HSSE en estuches metálicos

SET.2653.3  
 €  
 Stück piece

SET.2653.4  
 €  
 Stück piece

### SET.2653.5

Universal

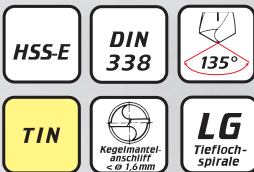

41 Stück pieces  
 $\varnothing$  6 - 10 mm  
 0,1 mm steigend rising 0,1 mm



HSS-E-Twist drills in metal cassettes

Zestawy wiertel skrętnych HSS-E w metalowej kasetce

Assortimenti di punte HSSE in cassetta metallica

Brocas HSSE en estuches metálicos

SET.2653.5  
 €  
 Stück piece



# HSS/HSSE-Spiralbohrer in Metallkassetten

## SET.2611.0

Universal

HSS

DIN  
338

TYP  
N

UNIVERSAL  
TOOL

41 Stück pieces  
Ø 6 - 10 mm  
0,1 mm steigend rising 0,1 mm



## SET.2611.1

Universal

HSS

DIN  
338

TYP  
N

TIN

UNIVERSAL  
TOOL

41 Stück pieces  
Ø 6 - 10 mm  
0,1 mm steigend rising 0,1 mm

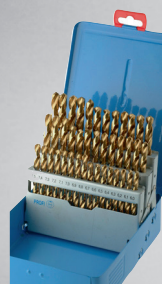

HSS-Twist drills in metal cassettes



Zestawy wiertel skrętnych HSS w metalowej kasetce



Assortimenti di punte HSS in cassetta metallica



Brocas HSS en estuches metálicos

SET.2611.0  
€  
Stück piece

SET.2611.1  
€  
Stück piece

## SET.2612.0

Universal

HSSE

DIN  
338

TYP  
N

UNIVERSAL  
TOOL

41 Stück pieces  
Ø 6 - 10 mm  
0,1 mm steigend rising 0,1 mm



## SET.2614.0

Universal

HSSE

DIN  
338

TYP  
N

UNIVERSAL  
TOOL

50 Stück pieces  
Ø 1 - 5,9 mm  
0,1 mm steigend rising 0,1 mm



HSSE-Twist drills in metal cassettes



Zestawy wiertel skrętnych HSSE w metalowej kasetce



Assortimenti di punte HSSE in cassetta metallica



Brocas HSSE en estuches metálicos

SET.2612.0  
€  
Stück piece

SET.2614.0  
€  
Stück piece

## SET.2613.0

Universal

HSS

DIN  
338

TYP  
N

OX

UNIVERSAL  
TOOL

50 Stück pieces  
Ø 1 - 5,9 mm  
0,1 mm steigend rising 0,1 mm



## SET.2613.1

Universal

HSS

DIN  
338

TYP  
N

TIN

UNIVERSAL  
TOOL

50 Stück pieces  
Ø 1 - 5,9 mm  
0,1 mm steigend rising 0,1 mm

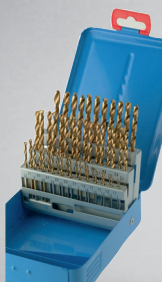

HSS-Twist drills in metal cassettes



Zestawy wiertel skrętnych HSS w metalowej kasetce



Assortimenti di punte HSS in cassetta metallica



Brocas HSS en estuches metálicos

SET.2613.0  
€  
Stück piece

SET.2613.1  
€  
Stück piece

Gewindebohrer  
1

Bohren HSSE  
2

Bohren VHM  
3

Reiben HSSE  
4

Reiben VHM  
5

Frässtifte VHM  
6

Fräsen VHM  
7

WP-Werkzeuge  
8

Fräsen HSSE  
9

Sägen  
10

Lehren  
11

Nachschleifen  
12

Sonstiges  
13



# HSSE-Spiralbohrer DIN 340

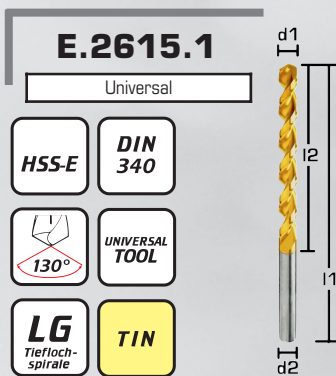

HSSE-Twist drills DIN 340

Wiertła skrotne HSS-E, wg DIN 340

Punta HSSE serie lunga DIN 340

Brocas serie larga DIN 340, HSSE

Artikel-Nr. Article-No.			E.2615.1	Artikel-Nr. Article-No.			E.2615.1
d1	l2	l1	€ Stück piece	d1	l2	l1	€ Stück piece
1,00	33	56		6,10	97	148	
1,10	37	60		6,20	97	148	
1,20	41	65		6,30	97	148	
1,30	41	65		6,40	97	148	
1,40	45	70		6,50	97	148	
1,50	45	70		6,60	97	148	
1,60	50	76		6,70	97	148	
1,70	50	76		6,80	102	156	
1,80	53	80		6,90	102	156	
1,90	53	80		7,00	102	156	
2,00	56	85		7,10	102	156	
2,10	56	85		7,20	102	156	
2,20	59	90		7,30	2	156	
2,30	59	90		7,40	102	156	
2,40	62	95		7,50	102	156	
2,50	62	95		7,60	109	165	
2,60	62	95		7,70	109	165	
2,70	66	100		7,80	109	165	
2,80	66	100		7,90	109	165	
2,90	66	100		8,00	109	165	
3,00	66	100		8,10	109	165	
3,10	69	106		8,20	109	165	
3,20	69	106		8,30	109	165	
3,30	69	106		8,40	109	165	
3,40	73	112		8,50	109	165	
3,50	73	112		8,60	115	175	
3,60	73	112		8,70	115	175	
3,70	73	112		8,80	115	175	
3,80	78	119		8,90	115	175	
3,90	78	119		9,00	115	175	
4,00	78	119		9,10	115	175	
4,10	78	119		9,20	115	175	
4,20	78	119		9,30	115	175	
4,30	82	126		9,40	115	175	
4,40	82	126		9,50	115	175	
4,50	82	126		9,60	121	184	
4,60	82	126		9,70	121	184	
4,70	82	126		9,80	121	184	
4,80	87	132		9,90	121	184	
4,90	87	132		10,00	121	184	
5,00	87	132		10,20	121	184	
5,10	87	132		10,50	121	184	
5,20	87	132		10,80	121	184	
5,30	87	132		11,00	128	195	
5,40	91	139		11,20	128	195	
5,50	91	139		11,50	128	195	
5,60	91	139		11,80	128	195	
5,70	91	139		12,00	134	205	
5,80	91	139		12,50	134	205	
5,90	91	139		13,00	134	205	
6,00	91	139					

# HSS/HSSE-Spiralbohrer überlang

**E.2616.0**  
Universal

HSS WERKS- (COMPANY) NORM  
UNIVERSAL TOOL  
130°  
LG Tiefloch-spirale XLANG XLONG

**E.2617.0**  
Universal

HSS-E WERKS- (COMPANY) NORM  
UNIVERSAL TOOL  
130°  
LG Tiefloch-spirale XLANG XLONG

HSS/HSSE-Twist drills extra long

Wiertła skrotne HSS/HSS-E, długie i bardzo długie wg normy zakładowej

Punte HSS/HSSE extra lunghe

Brocas extralargas, norma fábrica, en HSS/HSSE

**E.2616.0 = Auslaufartikel**

*E.2616.0 = no future production anymore*

Artikel-Nr.	Article-No.	E.2616.0 € Stück piece	E.2617.0 € Stück piece	Artikel-Nr.	Article-No.	E.2616.0 € Stück piece	E.2617.0 € Stück piece
d1				d1			
<b>12 x 11</b>		<b>93 x 125</b>		<b>5,20</b>			
2,00				5,30			
2,10				5,40			
2,20				5,50			
2,30				5,60			
2,40				5,70			
2,50				5,80			
2,60				5,90			
2,70				6,00			
2,80				6,10			
2,90				6,20			
3,00				6,30			
<b>12 x 11</b>		<b>120 x 160</b>		6,40			
2,00				6,50			
2,10				6,60			
2,20				6,70			
2,30				6,80			
2,40				6,90			
2,50				7,00			
2,90				7,10			
3,00				7,20			
3,30				7,30			
3,50				7,40			
4,00				7,50			
4,20				8,00			
4,50				8,50			
5,00				9,00			
6,00				9,50			
<b>12 x 11</b>		<b>150 x 200</b>		<b>10,00</b>			
3,00				<b>12 x 11</b>		<b>187 x 250</b>	
3,10				3,00			
3,20				3,10			
3,30				3,20			
3,40				3,30			
3,50				3,40			
3,60				3,50			
3,70				3,60			
3,80				3,70			
3,90				3,80			
4,00				3,90			
4,10				4,00			
4,20				4,10			
4,30				4,20			
4,40				4,30			
4,50				4,40			
4,60				4,50			
4,70				4,60			
4,80				4,70			
4,90				4,80			
5,00				4,90			
5,10				5,00			

- 1 Gewindebohrer
- 2 Bohren HSSE
- 3 Bohren VHM
- 4 Reiben HSSE
- 5 Reiben VHM
- 6 Frässtifte VHM
- 7 Fräsen VHM
- 8 WP-Werkzeuge
- 9 Fräsen HSSE
- 10 Sägen
- 11 Lehren
- 12 Nachschleifen
- 13 Sonstiges

# HSS/HSSE-Spiralbohrer überlang

**E.2616.0**

Universal

HSS WERKS-(COMPANY) NORM

130° UNIVERSAL TOOL

LG Tiefloch-spirale XLANG XLONG

**E.2617.0**

Universal

HSS-E WERKS-(COMPANY) NORM

130° UNIVERSAL TOOL

LG Tiefloch-spirale XLANG XLONG

HSS/HSSE-Twist drills extra long

Wiertła skrętnie HSS/HSS-E, długie i bardzo długie wg normy zakładowej

Punte HSS/HSSE extra lunghe

Brocas extralargas, norma fábrica, en HSS/HSSE

**E.2616.0 = Auslaufartikel**

*E.2616.0 = no future production anymore*

Artikel-Nr.	Article-No.	E.2616.0 € Stück piece	E.2617.0 € Stück piece	Artikel-Nr.	Article-No.	E.2616.0 € Stück piece	E.2617.0 € Stück piece
	d1				d1		
<b>Fortsetzung continuation 187 x 250</b>							
	5,10				5,40		
	5,20				5,50		
	5,30				5,60		
	5,40				5,70		
	5,50				5,80		
	5,60				5,90		
	5,70				6,00		
	5,80				6,10		
	5,90				6,20		
	6,00				6,30		
	6,10				6,40		
	6,20				6,50		
	6,30				6,60		
	6,40				6,70		
	6,50				6,80		
	6,60				6,90		
	6,70				7,00		
	6,80				7,10		
	6,90				7,20		
	7,00				7,30		
	7,10				7,40		
	7,20				7,50		
	7,30				8,00		
	7,40				8,50		
	7,50				9,00		
	8,00				9,50		
	8,50				10,00		
	9,00				10,50		
	9,50				11,00		
	10,00				11,50		
	10,50				12,00		
	11,00				12,50		
	11,50				13,00		
	12,00						
	12,50						
	13,00						
	<b>l2 x l1</b>	<b>235 x 315</b>				<b>300 x 400</b>	
	4,00				5,00		
	4,10				5,10		
	4,20				5,20		
	4,30				5,30		
	4,40				5,40		
	4,50				5,50		
	4,60				5,60		
	4,70				5,70		
	4,80				5,80		
	4,90				5,90		
	5,00				6,00		
	5,10				6,10		
	5,20				6,20		
	5,30				6,30		
					6,40		
					6,50		
					6,60		
					6,70		

## HSS/HSSE-Spiralbohrer überlang

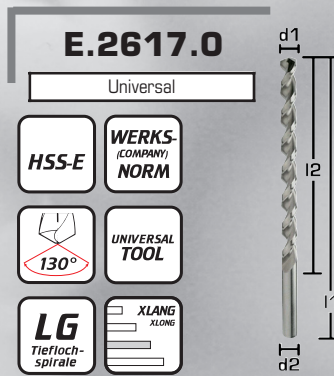
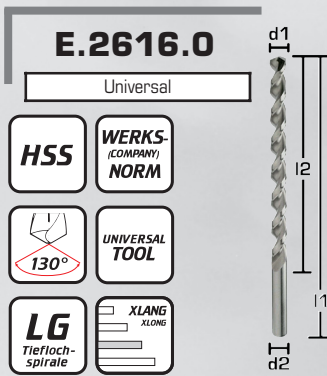

HSS/HSSE-Twist drills extra long

Wiertła skrętnie HSS/HSS-E, długie i bardzo długie wg normy zakładowej

Punte HSS/HSSE extra lunghe

Brocas extralargas, norma fábrica, en HSS/HSSE

E.2616.0 = Auslaufartikel

E.2616.0 = no future production anymore

Artikel-Nr.	Article-No.	E.2616.0 € Stück piece	E.2617.0 € Stück piece	Artikel-Nr.	Article-No.	E.2616.0 € Stück piece	E.2617.0 € Stück piece
d1				d1			
<b>Fortsetzung continuation 300 x 400</b>							
6,80				11,00			
6,90				11,50			
7,00				12,00			
7,10				12,50			
7,20				13,00			
7,30				l2 x l1		450 x 500	
7,40				5,00			
7,50				6,00			
8,00				7,00			
8,50				8,00			
9,00				9,00			
9,50				10,00			
10,00				11,00			
10,50				12,00			
				13,00			

## HSS-Spiralbohrer XXL

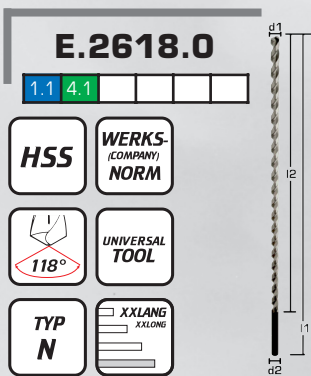

HSS-Twist drills XXL

Wiertła skrętnie HSS, XXL

Punte HSS serie XXL

Brocas extralargas XXL, norma fábrica, en HSS

Artikel-Nr. Article-No.			E.2618.0 € Stück piece
d1	l2	l1	
6,00	400	500	
8,00	400	500	
10,00	500	600	
11,00	500	600	
12,00	500	600	
<b>lang long</b>			<b>E.2618.0L</b>
8,00	650	750	
10,00	650	750	
11,00	650	750	
12,00	650	750	
<b>überlang extended long</b>			<b>E.2618.0XL</b>
10,00	850	1000	
11,00	850	1000	
12,00	850	1000	

- 1 Gewindebohrer
- 2 Bohren HSSE
- 3 Bohren VHM
- 4 Reiben HSSE
- 5 Reiben VHM
- 6 Frässtifte VHM
- 7 Fräsen VHM
- 8 WP-Werkzeuge
- 9 Fräsen HSSE
- 10 Sägen
- 11 Lehren
- 12 Nachschleifen
- 13 Sonstiges

# HSS-Spiralbohrer DIN 345

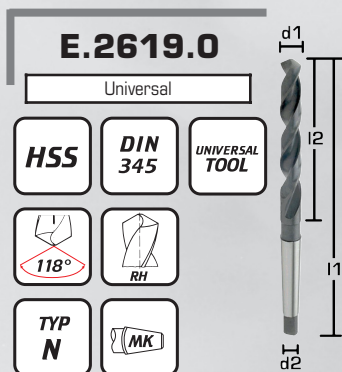

 HSS-Twist drills DIN 345

 Wiertła skrętnie HSS na stożku Morse'a, wg DIN 345

 Punte HSS DIN 345

 Brocas cónicas DIN 345 en HSS

Mit gefrästen Nuten  
With milled flutes

Artikel-Nr.		Article-No.		E.2619.0 € Stück piece	Artikel-Nr.		Article-No.		E.2619.0 € Stück piece	Artikel-Nr.		Article-No.		E.2619.0 € Stück piece
d1	l2	l1	d2 MK		d1	l2	l1	d2 MK		d1	l2	l1	d2 MK	
10,00	87	168	1		21,75	150	248	2		36,00	195	344	4	
10,25	87	168	1		22,00	150	148	2		37,00	195	344	4	
10,50	87	168	1		22,25	150	248	2		38,00	200	349	4	
10,75	94	175	1		22,50	155	253	2		39,00	200	349	4	
11,00	94	175	1		22,75	155	253	2		39,50	200	349	4	
11,25	94	175	1		23,00	155	253	2		40,00	200	349	4	
11,50	94	175	1		23,25	155	276	3		40,50	205	354	4	
11,75	94	175	1		23,50	155	276	3		41,00	205	354	4	
12,00	101	182	1		23,75	160	281	3		41,50	205	354	4	
12,25	101	182	1		24,00	160	281	3		42,00	205	354	4	
12,50	101	182	1		24,25	160	281	3		42,50	205	354	4	
12,75	101	182	1		24,50	160	281	3		43,00	210	359	4	
13,00	101	182	1		24,75	160	281	3		43,50	210	359	4	
13,25	108	189	1		25,00	160	281	3		44,00	210	359	4	
13,50	108	189	1		25,25	160	281	3		44,50	210	359	4	
13,75	108	189	1		25,50	165	286	3		45,00	210	359	4	
14,00	108	189	1		25,75	165	286	3		45,50	215	364	4	
14,25	114	212	2		26,00	165	286	3		46,00	215	364	4	
14,50	114	212	2		26,25	165	286	3		46,50	215	364	4	
14,75	114	212	2		26,50	165	286	3		47,00	215	364	4	
15,00	114	212	2		26,75	170	291	3		47,50	215	364	4	
15,25	120	218	2		27,00	170	291	3		48,00	220	369	4	
15,50	120	218	2		27,25	170	291	3		48,50	220	369	4	
15,75	120	218	2		27,50	170	291	3		49,00	220	369	4	
16,00	120	218	2		27,75	170	291	3		49,50	220	369	4	
16,25	125	223	2		28,00	170	291	3		50,00	220	369	4	
16,50	125	223	2		28,25	175	296	3		50,50	225	374	4	
16,75	125	223	2		28,50	175	296	3		51,00	225	412	5	
17,00	125	223	2		28,75	175	296	3		52,00	225	412	5	
17,25	130	228	2		29,00	175	296	3		53,00	225	412	5	
17,50	130	228	2		29,25	175	296	3		53,50	230	417	5	
17,75	130	228	2		29,50	175	296	3		54,00	230	417	5	
18,00	130	228	2		29,75	175	296	3		55,00	230	417	5	
18,25	135	233	2		30,00	175	296	3		56,00	230	417	5	
18,50	135	233	2		30,25	180	301	3		57,00	235	422	5	
18,75	135	233	2		30,50	180	301	3		58,00	235	422	5	
19,00	135	233	2		30,75	180	301	3		59,00	235	422	5	
19,25	140	238	2		31,00	180	301	3		60,00	235	422	5	
19,50	140	238	2		31,25	180	301	3		61,00	240	427	5	
19,75	140	238	2		31,50	180	301	3		62,00	240	427	5	
20,00	140	238	2		31,75	185	306	3		63,00	240	427	5	
20,25	145	243	2		32,00	185	334	4		65,00	245	432	5	
20,50	145	243	2		32,50	185	334	4		68,00	250	437	5	
20,75	145	243	2		33,00	185	334	4		70,00	250	437	5	
21,00	145	243	2		33,50	185	334	4		75,00	255	442	5	
21,25	150	248	2		34,00	190	339	4		80,00	260	514	6	
21,50	150	248	2		35,00	190	339	4		100,00	280	534	6	



# HSS-Spiralbohrer gefräst lang

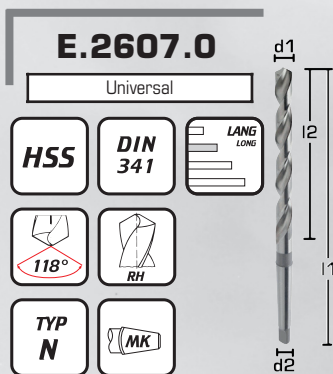

HSS-Twist drills milled quality long

Wiertła skrętnie frezowane HSS, długie

Punte HSS qualità fresata, serie lunga

Brocas cónicas, serie larga en HSS, fresadas a muela





Artikel-Nr. Article-No.				E.2607.0 € Stück piece
d1	l2	l1	d2 MK	
15,00	147	245	2	
16,00	153	251	2	
17,00	159	257	2	
18,00	165	263	2	
20,00	177	275	2	
21,00	184	282	2	
22,00	191	289	2	
23,00	198	296	2	
24,00	206	327	3	
25,00	206	327	3	
26,00	214	335	3	
27,00	222	343	3	
28,00	222	343	3	
29,00	230	351	3	
30,00	230	351	3	
32,00	248	397	4	
34,00	248	397	4	
36,00	267	416	4	
38,00	277	426	4	
40,00	277	426	4	
42,00	287	436	4	
45,00	298	447	4	
50,00	321	470	4	

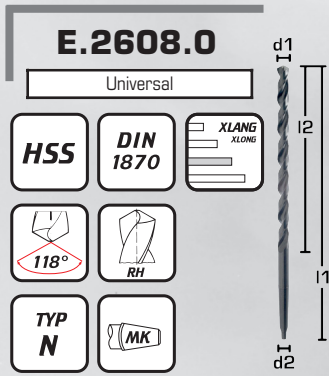

Gewindebohrer	1
Bohren HSSE	2
Bohren VHM	3
Reiben HSSE	4
Reiben VHM	5
Frässtifte VHM	6
Fräsen VHM	7
WP-Werkzeuge	8
Fräsen HSSE	9
Sägen	10
Lehren	11
Nachschleifen	12
Sonstiges	13

# HSS-Spiralbohrer gefräst XL



-  HSS-Twist drills milled quality XL
-  Wiertła skrotne frezowane HSS, XL
-  Punta HSS qualità fresata, serie extra lunga
-  Brocas cónicas, XL, en HSS, fresadas a muela

Artikel-Nr. Article-No.				E.2608.0 € Stück piece
d1	l2	l1	d2 MK	
12,00	205	310	1	
13,00	205	310	1	
14,00	220	325	1	
15,00	220	340	2	
16,00	230	355	2	
17,00	230	355	2	
18,00	245	370	2	
19,00	245	370	2	
20,00	260	385	2	
21,00	260	385	2	
22,00	270	405	2	
23,00	270	405	2	
24,00	290	440	3	
25,00	290	440	3	
26,00	290	440	3	
27,00	305	460	3	
28,00	305	460	3	
29,00	305	460	3	
30,00	305	460	3	
32,00	320	505	4	
35,00	340	530	4	
38,00	360	555	4	
40,00	360	555	4	
42,00	360	555	4	
45,00	385	585	4	
48,00	405	605	4	
50,00	405	605	4	

# HSS-Spiralbohrer gefräst XXL

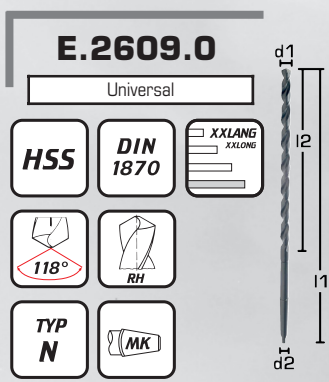

- HSS-Twist drills milled quality XXL
- Wiertła skrotne frezowane na stożku Morse'a, XXL
- Punte HSS qualità fresata, serie XXL
- Brocas cónicas, XXL, en HSS, fresadas a muela

Artikel-Nr. Article-No.				E.2609.0 € Stück piece
d1	l2	l1	d2 MK	
12,00	260	395	1	
13,00	260	395	1	
14,00	275	410	1	
15,00	275	425	2	
16,00	295	445	2	
17,00	295	445	2	
18,00	310	465	2	
20,00	325	490	2	
21,00	325	490	2	
22,00	345	515	2	
23,00	345	515	2	
24,00	365	555	3	
25,00	365	555	3	
26,00	365	555	3	
27,00	385	580	3	
28,00	385	580	3	
29,00	385	580	3	
30,00	385	580	3	
32,00	410	635	4	
35,00	430	665	4	
38,00	460	695	4	
40,00	460	695	4	
42,00	460	695	4	
45,00	490	735	4	
48,00	510	765	4	
50,00	510	765	4	

- Gewindebohrer 1
- Bohren HSSE 2
- Bohren VHM 3
- Reiben HSSE 4
- Reiben VHM 5
- Frässtifte VHM 6
- Fräsen VHM 7
- WP-Werkzeuge 8
- Fräsen HSSE 9
- Sägen 10
- Lehren 11
- Nachschleifen 12
- Sonstiges 13

## HSS-Zentrierbohrer 60°

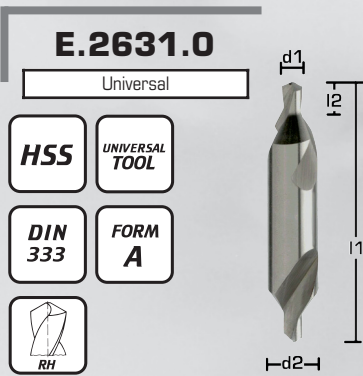

**E.2631.0**

Universal

**HSS**

UNIVERSAL  
TOOL

**DIN  
333**

**FORM  
A**

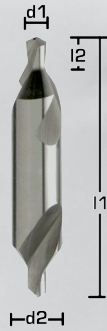

HSS-Center drills 60°

Nawiertaki HSS 60°

Punte da centro a 60°, HSS

Brocas de centar de 60°, HSS

\* = nur einseitig  
\* = only one side

Verpackungseinheit: bis Ø 3,15 mm 10 Stück/Abm.  
Unit size: up to Ø 3,15 mm 10 pieces/size

Artikel-Nr. Article-No.				E.2631.0 € Stück piece
d1 k12	l2 +- 1	l1	d2 h8	
0,50*	0,6 - 0,8	25	3,15	
0,80*	1,0 - 1,2	25	3,15	
1,00	1,3 - 1,6	31	3,15	
1,25	1,6 - 1,9	31	3,15	
1,60	2,0 - 2,4	35	4,00	
2,00	2,5 - 2,9	40	5,00	
2,50	3,1 - 3,6	45	6,30	
3,15	3,9 - 4,4	50	8,00	
4,00	5,0 - 5,6	55	10,00	
5,00	6,3 - 6,9	63	12,50	
6,30	8,0 - 8,6	71	16,00	
8,00	10,1 - 10,8	80	20,00	
10,00	12,8 - 13,5	100	25,00	

## HSS-Zentrierbohrer 60° im Satz

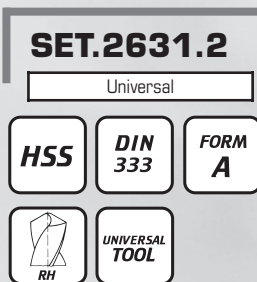

30 Stück pieces  
5 St. Ø 1 / 1,6 / 2 / 2,5 / 3,15 mm  
4 St. Ø 4 mm  
1 St. Ø 5 mm

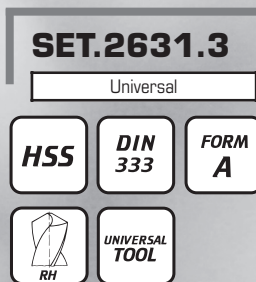

15 Stück pieces  
3 St. Ø 1 / 1,6 / 2 / 2,5 / 3,15 mm  
2 St. Ø 4 mm  
1 St. Ø 5 mm

Set of HSS-Center drills 60°

Zestaw nawiertaków HSS 60°

Assortimento punte da centro a 60°, HSS

Juego de brocas de centar de 60°, HSS

**SET.2631.2**  
€  
Stück piece

**SET.2631.3**  
€  
Stück piece

## HSS/HSSE-Zentrierbohrer 60°/120°

**E.2635.0**  
Universal

**HSS** UNIVERSAL TOOL

**DIN 333** FORM B

RH



**E.2636.0**  
Universal

**HSS** UNIVERSAL TOOL

**DIN 333** FORM B

LH



HSS-Center drills 60°/120°

Nawiertaki HSS 60°/120°

Punte da centro 60°/120°, HSS

Brocas de centrar de 60°/120°, HSS

Artikel-Nr. Article-No.				<b>E.2635.0</b> € Stück piece	<b>E.2636.0</b> € Stück piece
d1 k12	l2 + - 1	l1	d2 h8		
1,00	1,3 - 1,6	35	4,0		
1,25	1,6 - 1,9	40	5,0		
1,60	2,0 - 2,4	45	6,3		
2,00	2,5 - 2,9	50	8,0		
2,50	3,1 - 3,6	55	10,0		
3,15	3,9 - 4,4	63	11,2		
4,00	5,0 - 5,6	71	14,0		
5,00	6,3 - 6,9	80	18,0		

## HSS/HSSE-Zentrierbohrer 60°/120°

**E.2637.0**  
Universal

**HSS** UNIVERSAL TOOL

**DIN 333** FORM B

RH



**E.2638.0**  
Universal

**HSS-E** UNIVERSAL TOOL

**DIN 333** FORM B

RH



HSS-Center drills 60°/120°

Nawiertaki HSS 60°/120°

Punte da centro 60°/120°, HSS

Brocas de centrar de 60°/120°, HSS

Artikel-Nr. Article-No.				<b>E.2637.0</b> € Stück piece	<b>E.2638.0</b> € Stück piece
d1 k12	l2 + - 1	l1	d2 h8		
1,60	2,0 - 2,4	45	6,3		
2,00	2,5 - 2,9	50	8,0		
2,50	3,1 - 3,6	55	10,0		
3,15	3,9 - 4,4	63	11,2		
4,00	5,0 - 5,6	71	14,0		
5,00	6,3 - 6,9	80	18,0		

Gewindebohrer	1
Bohren HSSE	2
Bohren VHM	3
Reiben HSSE	4
Reiben VHM	5
Frässtifte VHM	6
Fräsen VHM	7
WP-Werkzeuge	8
Fräsen HSSE	9
Sägen	10
Lehren	11
Nachschleifen	12
Sonstiges	13



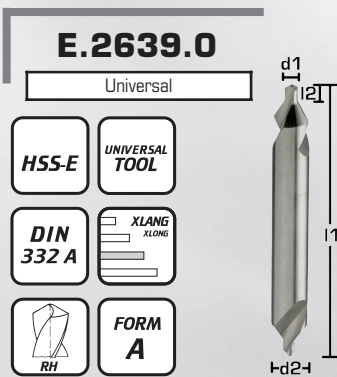

# HSSE-Zentrierbohrer 60° überlang



 HSSE-Center drills 60° extra long

 Nawiertaki HSS-E wydłużone 60°

 Punte da centro 60°/120°, HSSE, extra lunghe

 Brocas de centrar de 60°, HSSE, extralargas

Artikel-Nr. Article-No.			E.2639.0 € Stück piece
d1 k12	l1	d2 h8	
0,75	60	3,5	
0,75	120	3,5	
1,00	60	4,0	
1,00	100	4,0	
1,00	120	4,0	
1,00	150	4,0	
1,50	60	5,0	
1,50	100	5,0	
1,50	150	5,0	
2,00	80	6,0	
2,00	100	6,0	
2,00	120	6,0	
2,00	150	6,0	
2,00	200	5,0	
2,50	80	8,0	
2,50	100	8,0	
2,50	120	8,0	
2,50	150	8,0	
2,50	200	6,3	
3,00	80	8,0	
3,00	100	8,0	
3,00	100	10,0	
3,00	150	8,0	
3,00	150	10,0	
3,15	120	8,0	
3,15	120	10,0	
3,15	200	8,0	
4,00	100	10,0	
4,00	100	12,0	
4,00	120	10,0	
4,00	120	12,0	
4,00	150	10,0	
4,00	150	12,0	
4,00	200	10,0	
5,00	120	14,0	

## HSS/HSSE-Radiuszentrierbohrer 60°

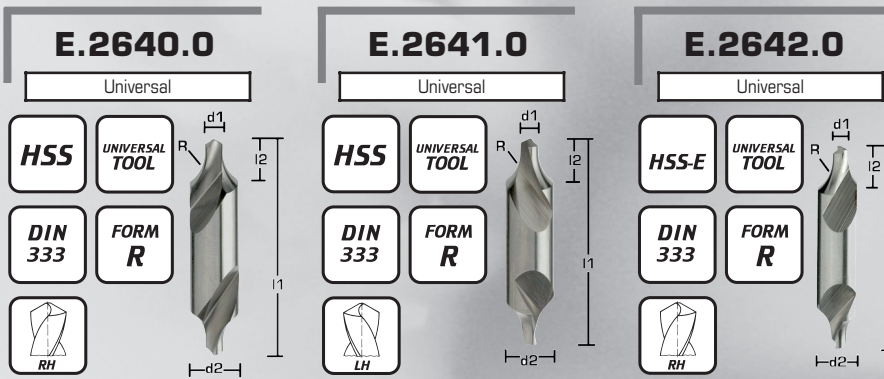

- HSS/HSSE-Ball nose center drills 60°
- Nawiertaki HSS/HSS-E 60° z czolem kulistym
- Punte da centro 60° con salvarraggio HSS/HSSE
- Broca de centrar de 60° con radio, HSS/HSSE

\* = nur einseitig  
\* = only one side

Artikel-Nr. Article-No.					E.2640.0	E.2641.0	E.2642.0
d1 k12	R	l2 + - 1	l1	d2 h8	€ Stück piece	€ Stück piece	€ Stück piece
0,50*	2,00	2,3 - 2,6	25	3,15			
0,80*	2,50	2,6 - 2,9	25	3,15			
1,00	2,90	3,0 - 3,3	31	3,15			
1,25	3,15	3,3 - 3,6	31	3,15			
1,60	4,00	4,2 - 4,7	35	4,00			
2,00	5,00	5,0 - 5,4	40	5,00			
2,50	6,30	6,3 - 6,8	45	6,30			
3,15	8,00	8,0 - 8,5	50	8,00			
4,00	10,00	10,0 - 10,6	55	10,00			
5,00	12,50	12,5 - 13,1	63	12,50			
6,30	16,00	16,0 - 16,6	71	16,00			
8,00	20,00	20,0 - 20,7	80	20,00			
10,00	25,00	25,0 - 25,7	100	25,00			

## HSSE-Kurzstufenbohrer 90° Kernloch

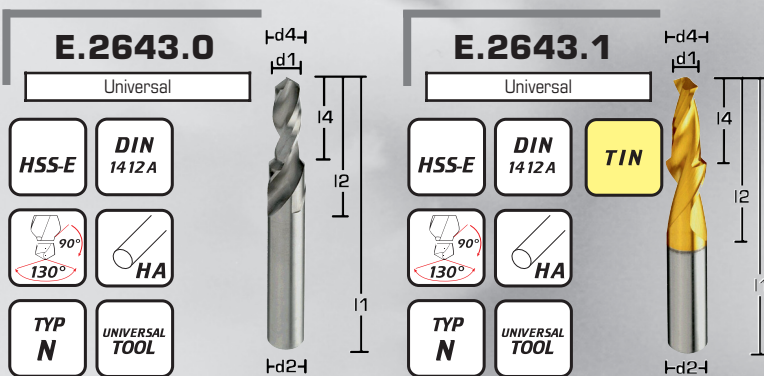





- HSSE-Short step drills 90° core hole
- Wiertła krótkie stopniowe HSS-E pod gwint dla śrub z łbem stożkowym 90°
- Punte a gradino , corte, 90° per filettatura
- Broca escalonada 90° para agujeros previos, HSSE

Artikel-Nr. Article-No.							E.2643.0	E.2643.1
Gewinde thread	d1	l4	d4	l2	l1 + - 1	d2	€ Stück piece	€ Stück piece
M 3,0	2,5	8	3,4	20	52	3,4		
M 4,0	3,3	11	4,5	24	58	4,5		
M 5,0	4,2	13	5,5	28	66	5,5		
M 6,0	5,0	16	6,6	31	70	6,6		
M 8,0	6,8	20	9,0	40	81	9,0		
M 10,0	8,5	24	11,0	47	95	11,0		
M 12,0	10,2	29	14,0	54	107	14,0		

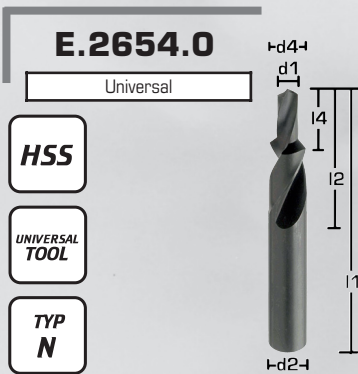
- 1 Gewindebohrer
- 2 Bohren HSSE
- 3 Bohren VHM
- 4 Reiben HSSE
- 5 Reiben VHM
- 6 Frässtifte VHM
- 7 Fräsen VHM
- 8 WP-Werkzeuge
- 9 Fräsen HSSE
- 10 Sägen
- 11 Lehren
- 12 Nachschleifen
- 13 Sonstiges

## HSS-Kurzstufenbohrer 90° fein





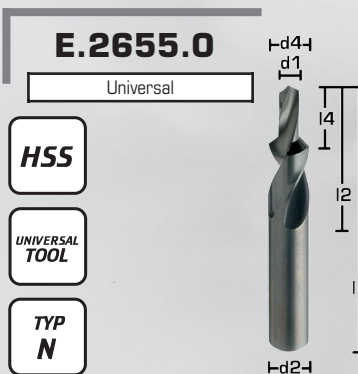

-  HSS-Short step drills 90° fine
-  Wiertła stopniowe HSS krótkie 90°, do otworów dokładnych
-  Punte a gradino HSS 90°, fine
-  Broca escalonada 90°, fino, HSS

Artikel-Nr. Article-No.							E.2654.0 € Stück piece
Gewinde thread	d1	l4	d4	l2	l1 + - 1	d2	
M 3,0	3,2	9	6,0	28	66	6,0	
M 4,0	4,3	11	8,0	37	79	8,0	
M 5,0	5,3	13	10,0	43	89	10,0	
M 6,0	6,4	15	11,5	47	95	11,5	
M 8,0	8,4	19	15,0	56	111	15,0	
M 10,0	10,5	23	19,0	64	127	19,0	

## HSS-Kurzstufenbohrer 90° mittel







-  HSS-Short step drills 90° medium
-  Wiertła stopniowe HSS krótkie 90°, do otworów średnio-dokładnych
-  Punte a gradino HSS 90°, medio
-  Broca escalonada 90°, medio, HSS

Artikel-Nr. Article-No.							E.2655.0 € Stück piece
Gewinde thread	d1	l4	d4	l2	l1 + - 1	d2	
M 3,0	3,4	6,6	9	31	70	6,6	
M 4,0	4,5	9,0	11	40	84	9,0	
M 5,0	5,5	11,0	13	47	95	11,0	
M 6,0	6,6	13,0	15	51	105	13,0	
M 8,0	9,0	17,2	19	62	123	17,2	
M 10,0	11,0	21,5	23	70	141	21,5	

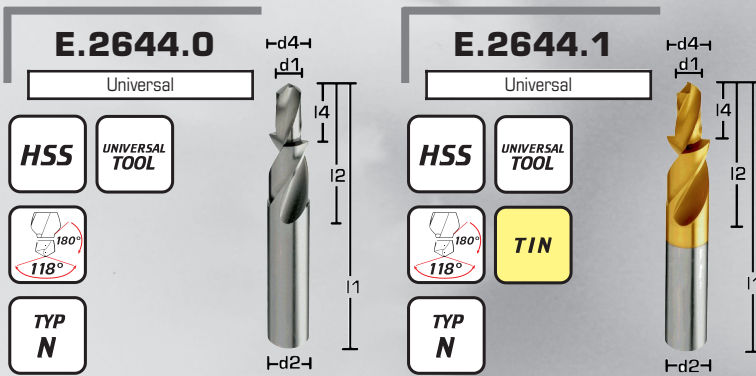
Mehrfasenstufenbohrer DIN 8374, 8376, 8378, 8375, 8377 und 8379 kurzfristig lieferbar  
Multiple margins step drills DIN 8374, 8376, 8378, 8375, 8377 and 8379 with short delivery time

## HSS-Kurzstufenbohrer 180°





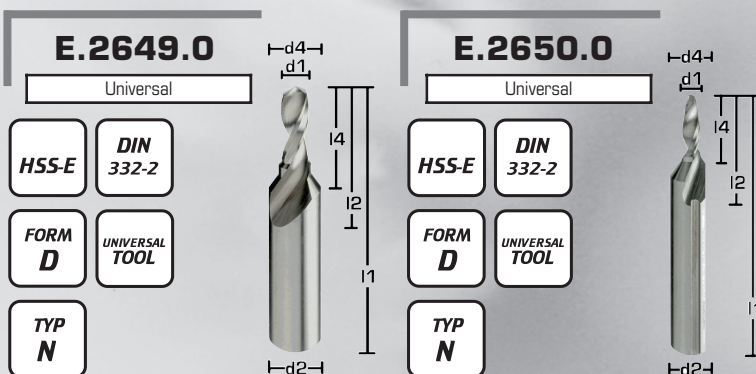

-  HSS-Short step drills 180°
-  Wiertła stopniowe HSS krótkie 180°
-  Punte a gradino HSS 180°, corte
-  Broca escalonada 180°, HSS

Artikel-Nr. Article-No.							E.2644.0	E.2644.1
Gewinde thread	d1 + - 0,05	l4	d4	l2	l1 + - 1	d2	€ Stück piece	€ Stück piece
M 3,0	3,4	6	9	28	66	6		
M 4,0	4,5	8	11	37	79	8		
M 5,0	5,5	10	13	43	89	10		
M 6,0	6,6	11	15	47	95	11		
M 8,0	9,0	15	19	56	111	15		
M 10,0	11,0	18	23	62	127	18		

## HSSE-Stufenbohrer für Kernlochzentrierungen



-  HSSE-Step drills for core hole centering
-  Wiertła stopniowe HSS-E do fazowania nakiełków
-  Punte a gradino HSSE per accentrare fori
-  Broca escalonada HSSE para centrar agujeros previos





Für Kernlochzentrierungen 90°/60°  
For core hole centering 90°/60°

Artikel-Nr. Article-No.							E.2649.0	E.2650.0
Gewinde thread	d1	l4	d4	l2	l1	d2	€ Stück piece	€ Stück piece
M 3,0	2,5	3,2	9,0	18	55	6,0		
M 4,0	3,3	4,3	12,6	23	63	8,0		
M 5,0	4,2	5,3	15,1	27	67	10,0		
M 6,0	5,0	6,4	18,9	33	71	12,5		
M 8,0	6,8	8,4	23,0	41	88	14,0		
M 10,0	8,5	10,5	27,7	47	90	16,0		
M 12,0	10,2	13,0	34,5	59	105	20,0		
M 16,0	14,0	17,0	41,3	67	132	25,0		
M 20,0	17,5	21,0	48,3	77	145	31,5		
M 24,0	21,0	25,0	57,0	90	160	40,0		

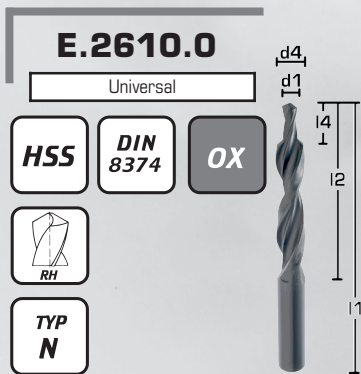
- Gewindebohrer 1
- Bohren HSSE 2
- Bohren VHM 3
- Reiben HSSE 4
- Reiben VHM 5
- Frässtifte VHM 6
- Fräsen VHM 7
- WP-Werkzeuge 8
- Fräsen HSSE 9
- Sägen 10
- Lehren 11
- Nachschleifen 12
- Sonstiges 13

## HSS-Mehrfasenstufenbohrer fein 90°





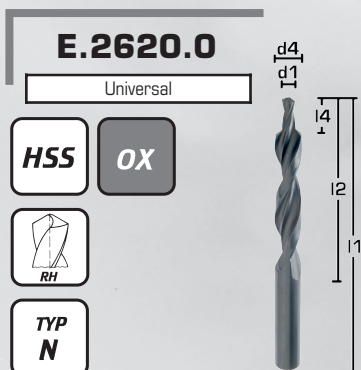

-  HSS-Subland drills 90° fine
-  Wiertła stopniowe HSS 90°, do otworów dokładnych
-  Punte a gradino HSS 90°, fine
-  Broca bidiametral, 90°, fino, HSS

Artikel-Nr. Article-No.						E.2610.0 € Stück piece
für Gewinde for thread	d1	l4	d4	l2	l1	
M 3	3,2	9,0	6,0	57	93	
M 4	4,3	11,0	8,0	75	117	
M 5	5,3	13,0	10,0	87	133	
M 6	6,4	15,0	11,5	94	142	
M 8	8,4	19,0	15,5	114	169	
M 10	10,5	23,0	19,0	135	198	

## HSS-Mehrfasenstufenbohrer 90° mittel



-  HSS-Subland drills 90° middle
-  Wiertła stopniowe HSS 90°, do otworów średnio-dokładnych
-  Punte a gradino HSS, multifase 90°, medio
-  Broca bidiametral, 90°, medio, HSS

Artikel-Nr. Article-No.						E.2620.0 € Stück piece
für Gewinde for thread	d1	l4	d4	l2	l1	
M 3	3,4	9,0	6,6	63	101	
M 4	4,5	11,0	9,0	81	125	
M 5	5,5	13,0	11,0	94	142	
M 6	6,6	15,0	13,0	101	151	
M 8	9,0	19,0	17,2	130	191	



## HSS-Mehrfasenstufenbohrer 90°

**E.2611.0**

Universal



HSS-Subland drills 90°

Wiertła stopniowe HSS 90°

Punte a gradino HSS, multifase 90°

Broca bidiametral 90°, HSS

Artikel-Nr. Article-No.						E.2611.0 € Stück piece
für Gewinde for thread	d1	l4	d4	l2	l1	
M 3	2,5	8,8	3,4	39	70	
M 4	3,3	11,4	4,5	47	80	
M 5	4,2	13,6	5,5	57	93	
M 6	5,0	16,5	6,6	63	101	
M 8	6,8	21,0	9,0	81	125	
M 10	8,5	25,5	11,0	94	142	
M 12	10,2	30,0	13,5	108	160	

## HSS-Mehrfasenstufenbohrer 180°

**E.2645.0**

Universal



HSS-Subland drills 180°

Wiertła stopniowe HSS 180°

Punte a gradino HSS, multifase 180°

Broca bidiametral 180°, HSS

Artikel-Nr. Article-No.						E.2645.0 € Stück piece
für Gewinde for thread	d1	l4	d4	l2	l1	
M 3	3,4	9,0	6,0	57	93	
M 4	4,5	11,0	8,0	75	117	
M 5	5,5	13,0	10,0	87	133	
M 6	6,6	15,0	11,0	94	142	
M 8	9,0	19,0	15,0	114	169	
M 10	11,0	23,0	18,0	130	191	

- Gewindebohrer 1
- Bohren HSSE 2
- Bohren VHM 3
- Reiben HSSE 4
- Reiben VHM 5
- Frässtifte VHM 6
- Fräsen VHM 7
- WP-Werkzeuge 8
- Fräsen HSSE 9
- Sägen 10
- Lehren 11
- Nachschleifen 12
- Sonstiges 13

## HSS-Mehrfasenstufenbohrer 90°

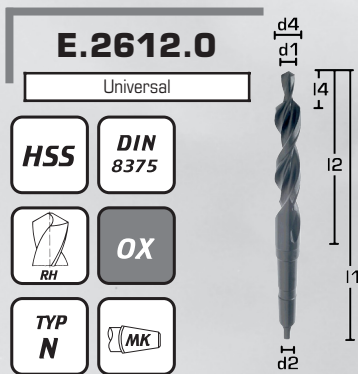

HSS-Subland drills 90°

Wiertła skrętne 90° HSS na stożku Morse'a

Punte a gradino HSS, multifase 90°

Broca bidiametral 90°, HSS

Artikel-Nr. Article-No.							E.2612.0 € Stück piece
für Gewinde for thread	d1	l4	d4	l2	l1	d2 MK	
<b>M 5</b>	5,5	13	11,0	94	175	1	
<b>M 6</b>	6,6	15	13,0	101	182	1	
<b>M 8</b>	9,0	19	17,2	130	228	2	
<b>M 10</b>	11,0	23	21,5	150	248	2	
<b>M 12</b>	14,0	27	26,0	165	286	3	
<b>M 14</b>	16,0	31	29,0	175	296	3	

## HSS-Mehrfasenstufenbohrer 180°

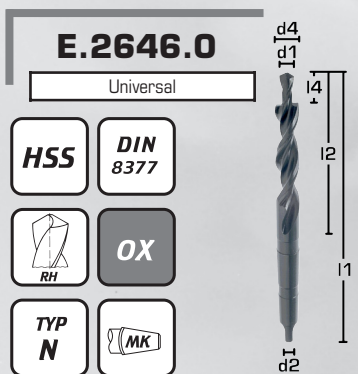

HSS-Subland drills 180°

Wiertła skrętne 180° HSS na stożku Morse'a





Punte a gradino HSS, multifase 180°

Broca bidiametral 180°, HSS

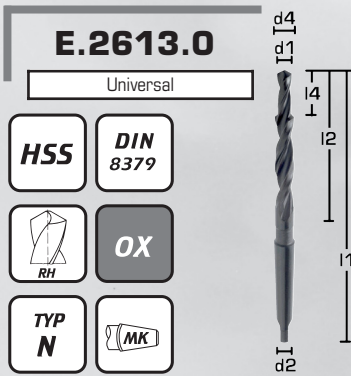
Artikel-Nr. Article-No.							E.2646.0 € Stück piece
für Gewinde for thread	d1	l4	d4	l2	l1	d2 MK	
<b>M 5</b>	5,5	13	10,0	87	168	1	
<b>M 6</b>	6,6	15	11,0	94	175	1	
<b>M 8</b>	9,0	19	15,0	114	212	2	
<b>M 10</b>	11,0	23	18,0	130	228	2	
<b>M 12</b>	13,5	27	20,0	140	238	2	
<b>M 14</b>	15,5	31	24,0	160	281	3	
<b>M 16</b>	17,5	35	26,0	165	286	3	
<b>M 18</b>	20,0	39	30,0	175	296	3	
<b>M 20</b>	22,0	43	33,0	185	334	4	

# HSS-Mehrfasenstufenbohrer 90°



-  HSS-Subland drills 90°
-  Wiertła skrętne 90° HSS na stożku Morse'a
-  Punte a gradino HSS, multifase 90°
-  Broca bidiametral 90°, HSS

Artikel-Nr. Article-No.							E.2613.0 € Stück piece
für Gewinde for thread	d1	l4	d4	l2	l1	d2 MK	
<b>M 8</b>	6,8	21,0	9,0	81	162	1	
<b>M 10</b>	8,5	25,5	11,0	94	175	1	
<b>M 12</b>	10,2	30,0	13,5	108	189	1	
<b>M 14</b>	12,0	34,5	15,5	120	218	2	
<b>M 16</b>	14,0	38,5	17,5	130	228	2	
<b>M 18</b>	15,5	43,5	20,0	140	238	2	
<b>M 20</b>	17,5	47,5	22,0	150	248	2	



- Gewindebohrer 1
- Bohren HSSE 2
- Bohren VHM 3
- Reiben HSSE 4
- Reiben VHM 5
- Frässtifte VHM 6
- Fräsen VHM 7
- WP-Werkzeuge 8
- Fräsen HSSE 9
- Sägen 10
- Lehren 11
- Nachschleifen 12
- Sonstiges 13

## HSSE-Kernbohrer

**E.2614.0**



HSS-E



HSSE-Core cutters

Wiertła trepanacyjne HSS-E

Punte a svasare, HSSE

Broca escariador HSSE

Artikel-Nr. Article-No.		E.2614.0 € Stück piece	Artikel-Nr. Article-No.		E.2614.0 € Stück piece
d1	Zähne flutes		d1	Zähne flutes	
20,00	6		37,00	10	
21,00	6		38,00	10	
22,00	6		39,00	10	
23,00	6		40,00	10	
24,00	6		41,00	12	
25,00	8		42,00	12	
26,00	8		43,00	12	
27,00	8		44,00	12	
28,00	8		45,00	12	
29,00	8		46,00	12	
30,00	8		47,00	12	
31,00	8		48,00	12	
32,00	8		49,00	12	
33,00	10		50,00	14	
34,00	10		51,00	14	
35,00	10		52,00	14	
36,00	10				

## Aufnahme für Kernbohrer

**E.2624.0**

HSS-E



Boring bar for core cutters

Uchwyt do wiertel trepanacyjnych pod chwyt stożek Morse'a

Barre per svasatori

Barra para brocas escariadores

Artikel-Nr. Article-No.			E.2624.0 € Stück piece
d1 +0,01	d2	l1	
19,05	20,0	112	
<b>MK-Schaft</b> MT-shank			
19,05	2	145	
19,05	3	166	

## Einsatzrichtwerte für HSS/HSSE-Bohrer *Estimated values for use for HSS/HSSE-Drills*

VR/fz	Vorschub (mm/U) <i>feed (mm/U)</i>														
	< Ø 0,5	< Ø 1	< Ø 2	< Ø 2,5	< Ø 3	< Ø 4	< Ø 5	< Ø 6	< Ø 8	< Ø 10	< Ø 12	< Ø 16	< Ø 20	< Ø 25	< Ø 30
1	0,004	0,006	0,020	0,025	0,032	0,040	0,040	0,050	0,063	0,080	0,080	0,100	0,125	0,160	0,160
2	0,006	0,008	0,025	0,032	0,040	0,050	0,050	0,063	0,080	0,100	0,100	0,125	0,160	0,200	0,200
3	0,007	0,012	0,032	0,040	0,050	0,063	0,063	0,080	0,100	0,15	0,125	0,160	0,200	0,250	0,250
4	0,008	0,014	0,040	0,050	0,063	0,080	0,080	0,100	0,125	0,160	0,160	0,200	0,250	0,315	0,315
5	0,010	0,016	0,050	0,063	0,080	0,100	0,100	0,125	0,160	0,200	0,200	0,250	0,315	0,400	0,400
6	0,012	0,018	0,063	0,080	0,100	0,125	0,125	0,160	0,200	0,250	0,250	0,315	0,400	0,500	0,500
7	0,014	0,020	0,080	0,100	0,125	0,160	0,160	0,200	0,250	0,315	0,315	0,400	0,500	0,630	0,630
8	0,016	0,023	0,100	0,125	0,160	0,200	0,200	0,250	0,315	0,400	0,400	0,500	0,630	0,800	0,800
9	0,019	0,025	0,125	0,160	0,160	0,200	0,250	0,315	0,315	0,400	0,500	0,630	0,630	0,800	1,000

Materialgruppe <i>material group</i>	Bohrer drills HSS blank uncoated OX black DIN 1897/338/345		Bohrer drills HSSE/Inox/Alu blank uncoated DIN 1897/338		Bohrer drills HSSE TIN DIN 1897/338		Bohrer drills HSSE BlueCut DIN 1897/338		Bohrer drills HSSE TIN DIN 340		Bohrer drills HSSE blank uncoated DIN 1870/>1870	
	Vc (m/min)	VR / fz	Vc (m/min)	VR / fz	Vc (m/min)	VR / fz	Vc (m/min)	VR / fz	Vc (m/min)	VR	Vc (m/min)	VR
1.1	18	6			30	5			30	6	22	4
1.2	15	3	20	5	25	5	25	6	20	6	20	4
1.3			14	3	18	4	20	4	20	4	12	3
2.1			15	4	20	4	20	4	14	3	8	2
2.2			10	3	10	2	10	3	10	2		
3.1	30	6	28	6	35	6			30	6	25	5
3.2	25	4										
3.3	20	4					50	6	25	5		
3.4									20	5		
4.1	80	7	60	6	70	7	100	8	60	6	70	6
4.2	60	7	50	5	60	6	100	8	60	6	50	6
4.3	45	5	40	5	50	6	80	7	50	6	40	5
4.4									60	6		
4.5							50	6	30	4		
4.6							50	6				
4.7	15	4	18	4	28	4	30	5	20	4	15	3
4.8												
4.9												
5.1			10	2	10	2	10	2	10	1	6	1
5.2			6	2					15	2		
6.1					4	1	4	2				
6.2												
6.3												
6.4												